

# ALGO

Communication Solutions

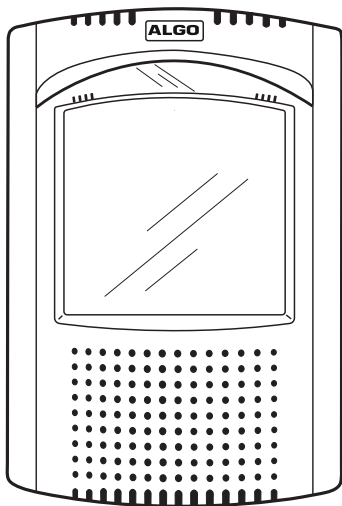

## **8036 SIP Multimedia Intercom**

### **User Guide**

Algo Communication Products Ltd.

[www.algosolutions.com](http://www.algosolutions.com)

# Table of Contents

<b>Overview .....</b>	<b>4</b>
<i>Introduction .....</i>	<i>4</i>
<i>Key Features.....</i>	<i>4</i>
<i>What's Included .....</i>	<i>5</i>
<i>Product Tour.....</i>	<i>6</i>
<b>Setup and Installation.....</b>	<b>7</b>
<i>Wall Mounting .....</i>	<i>7</i>
<i>PoE Network Connection.....</i>	<i>15</i>
<b>Programming and Configuration.....</b>	<b>16</b>
<i>Web Interface Control Panel .....</i>	<i>16</i>
<i>Accessing the Control Panel.....</i>	<i>16</i>
<i>Setup SIP Account.....</i>	<i>18</i>
<b>Application Development.....</b>	<b>19</b>
<i>Overview .....</i>	<i>19</i>
<i>Creating User Interface Screens .....</i>	<i>20</i>
<i>Custom Graphic Screens.....</i>	<i>20</i>
<i>Directory (Addressbook) Listings .....</i>	<i>21</i>
<i>Uploading user content .....</i>	<i>22</i>
<b>Control Panel Menu Reference.....</b>	<b>23</b>
<i>Status.....</i>	<i>23</i>
<i>Settings .....</i>	<i>24</i>
<i>User Interface.....</i>	<i>33</i>
<i>System .....</i>	<i>42</i>
<b>Door Control .....</b>	<b>45</b>
<i>Configuring the 8061 .....</i>	<i>46</i>
<i>Configuring the 8036 with the 8061 .....</i>	<i>47</i>
<i>Door Control Hardware and Wiring .....</i>	<i>47</i>
<b>Appendix .....</b>	<b>48</b>
<i>Upgrade 8036 Firmware .....</i>	<i>48</i>
<i>Soft Reset .....</i>	<i>49</i>
<i>Button Positioning Table.....</i>	<i>50</i>

<i>Directory (Addressbook) Text Files</i> .....	53
<i>Working with Compressed Files</i> .....	55
<i>Specifications</i> .....	57
<i>FCC Compliance</i> .....	59
<i>Important Safety Notice</i> .....	59

# Overview

## Introduction

The 8036 is a multimedia SIP endpoint from Algo combining the functionality of an IP phone, security camera, and interactive kiosk. Easily configurable to support multiple applications and interface configurations, the product is designed for outdoor or public access locations to provide enhanced communication and support for guests and visitors.

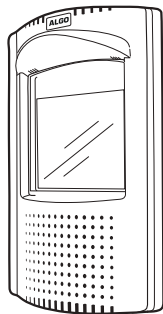

## Key Features

- Sunlight viewable 5.7" VGA color capacitive touch display
- Integrated camera for still snapshot or H.264 video streaming
- Weatherproof
- Wideband speaker and dual microphones
- Presence detection
- Secure door/gate management
- Web interface panel for configuration and application programming

---

For comprehensive product and application information, please visit [www.algosolutions.com/8036](http://www.algosolutions.com/8036)

## What's Included

For information on the use of each of these components, please refer to "Setup and Installation" on page 7.

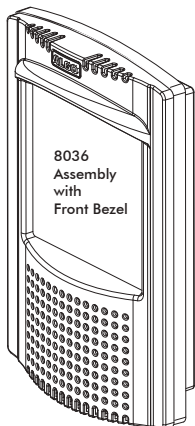

Ethernet  
Cable Boot



Algo  
Security  
Tool

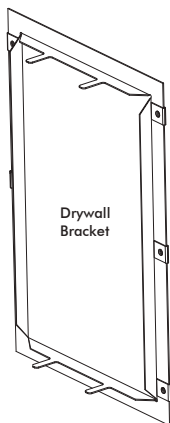
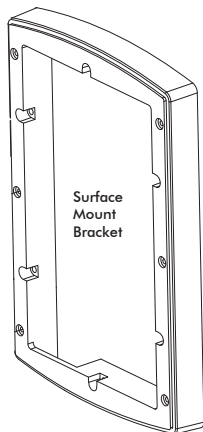

#8 x 1.5  
Type A  
Pan Head  
Phillips  
Qty: 6



#8 x 1  
Type B  
Pan Head  
Phillips  
Qty: 6



# Product Tour

---

## Front View

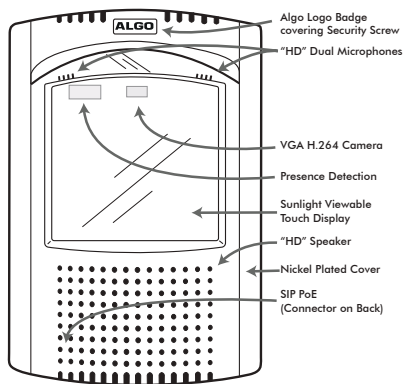

## Back View (of 8036 Assembly)

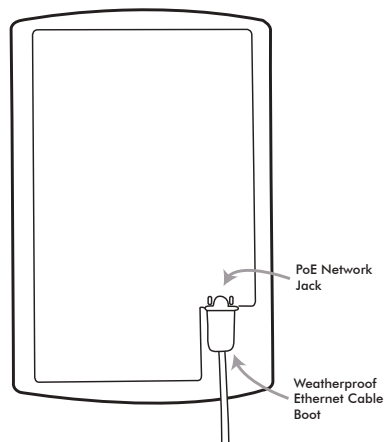

# Setup and Installation

This section will guide you with the physical installation of your new 8036 SIP Multimedia Intercom.

## Wall Mounting

The 8036 can be either surface or flush mounted. The unit is designed to shed rainwater and allow air ventilation only when oriented in the correct position (ALGO logo at top) and installed vertically.

### **Removal of Front Bezel for Installation**

The 8036 is shipped partially assembled and must be partially disassembled before it can be installed.

Remove the security screw behind the ALGO Logo Badge by first pressing on one side of the badge. This will raise the other side so that it can be removed easily by hand.

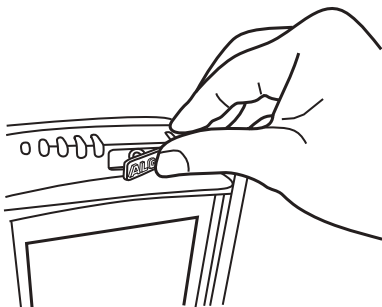

A security bit (“Algo Security Tool”) is included with the 8036 that fits standard socket screwdrivers. Use the bit in a screwdriver to remove the security screw and carefully remove the Front Bezel by pulling at the top and then disengaging the bottom clip.

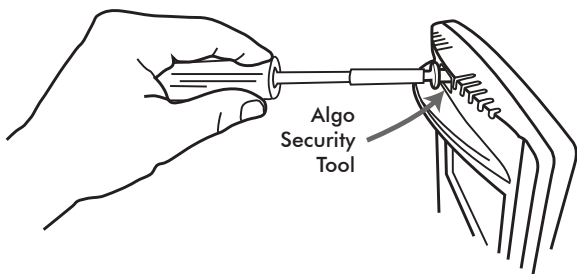

Put the Front Bezel, Security Screw, and Logo Badge aside for re-assembly after mounting.

Refer to the following diagrams for the appropriate methods and components to use for different mounting applications.

### ***Flush Mounting into Drywall (Interior)***

1. Create a drywall cut out per the template on page 4 of this sheet.
2. Place the Drywall Bracket into wall and bend tabs around to the front of the drywall to hold in place.
3. After connecting the Ethernet cable, use the #8 x 1.5" Type A Pan Head screws to secure the 8036 housing to the Drywall Bracket.
4. Replace the Front Bezel and keep the Algo Security Tool in a safe location.
5. Replace the ALGO Logo Badge.



*The Mounting Gasket and Surface Mount Bracket are not required for drywall mounting.*



Flush Mounting an 8036 into an interior wall (drywall)

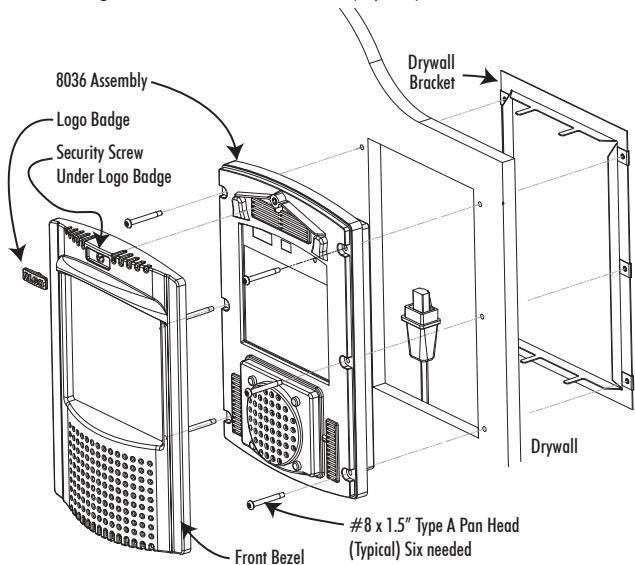

A template for cutting a hole in the wall can be downloaded at [www.algosolutions.com/8036mounting](http://www.algosolutions.com/8036mounting)

## **Flush Mounting into Other Materials or Outdoors**

The same guidelines of flush mounting from the previous section apply, however, the Drywall Bracket may not be required if the wall material is firm enough to hold a screw close to the cutout edge. A #8 anchor may be required (not supplied) for the wall material.

### **If outdoors:**

1. A rubber Ethernet Cable boot is supplied to be placed over the network cable prior to terminating with a plug (see "PoE Network Connection" on page 15).
2. While the 8036 is designed to withstand rain, it may be undesirable for water to enter the wall cavity. This can be achieved by sealing the cable hole prior to mounting or using the Mounting Gasket between the 8036 and wall. Uneven surfaces may require a silicon bead around the 8036 after installation.

---

### *Flush Mounting an 8036 into Drywall*

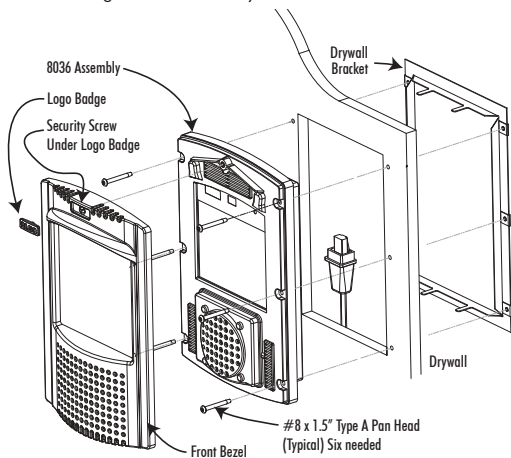

*Flush Mounting an 8036 into Drywall*

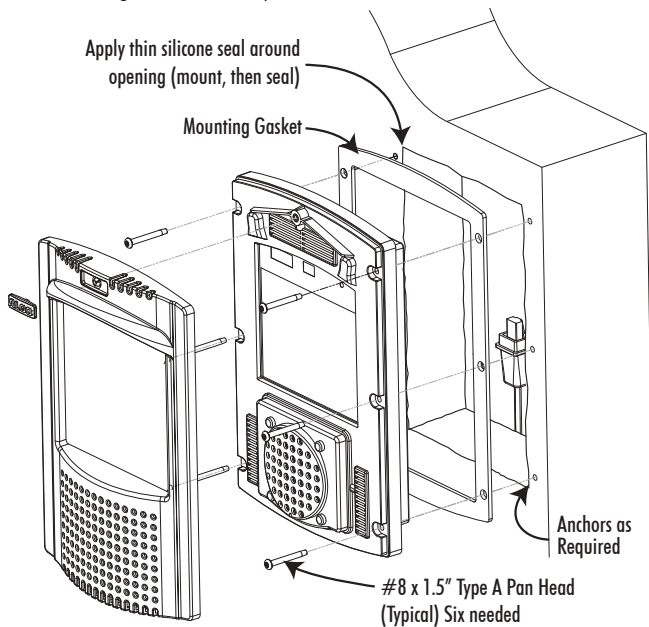

## Surface Mounting

The Surface Mount Bracket may be used on a wall surface where flush mounting is undesirable, or not practical. The bracket also may be good option when integrating the 8036 into stonework.

1. Mount the Surface Mount Bracket using the #8 x 1.5" Type A Pan Head screws supplied. For some wall materials, #8 anchors may be required (not included).



*There is a top and bottom to the Surface Mount Bracket. Make sure the two drainage holes are at the bottom.*

### If outdoors:

- a. Ensure any opening in the wall is sealed or apply a silicon bead between the Surface Mount Bracket and wall surface around the outside perimeter.
  - b. The Ethernet Cable Boot is to be placed over the network cable prior to terminating with a plug (see "PoE Network Connection" on page 15).
  - c. To prevent water from getting behind the 8036, place the Mounting Gasket on to the back of the 8036 housing prior to mounting.
2. After connecting the Ethernet cable, use the #8 x 1" Type B Pan Head screws to secure the 8036 housing to the Surface Mount Bracket.
  3. Replace the Front Bezel and keep the Algo Security Tool in a safe location. Replace the ALGO Logo Badge.



*The Drywall Bracket is not required when surface mounting.*

Surface mounting an 8036 on outside wall

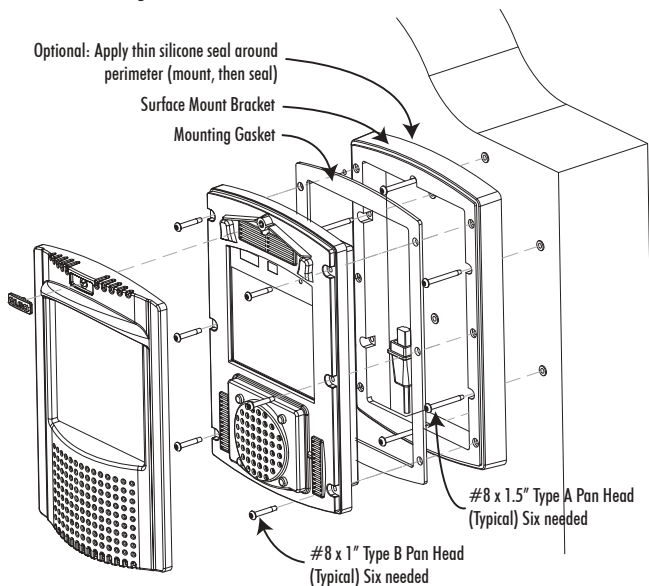

## Mounting Height

The 8036 should be mounted at an appropriate height for your intended application. The considerations are:

1. Easy readability of the interface screens for users of different heights
2. Highest quality camera and video images.

For most applications, a mounting height of approximately 55 inches (1.4 m) from floor to center of display is recommended.

*Mounting the 8036 at the proper height*

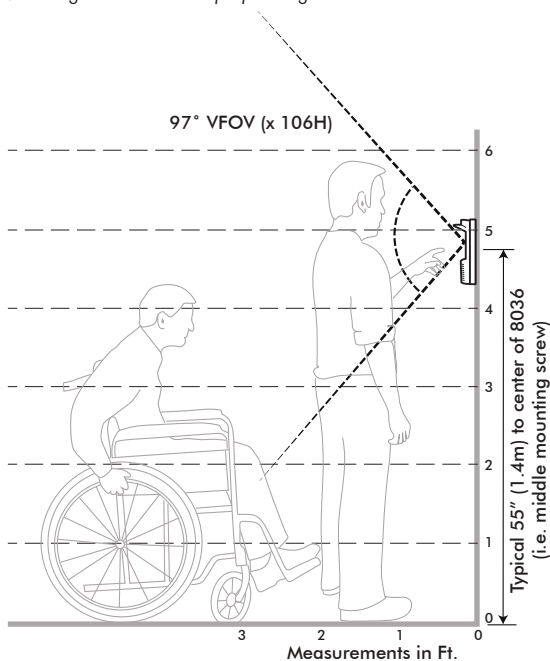

## PoE Network Connection

The 8036 is powered by the Ethernet PoE network connection. Typically a network cable is run to the 8036 location and then terminated with a male RJ45 plug.



*If you don't have a PoE switch, you'll need a PoE injector that installs between the 8036 and the network switch. The PoE injector will supply 48 Vdc to the 8036. Ensure that the PoE injector is fully compliant to the IEEE 802.3af standard.*

If mounting outdoors, slide the Ethernet Cable Boot onto the cable before installing the RJ45 plug.

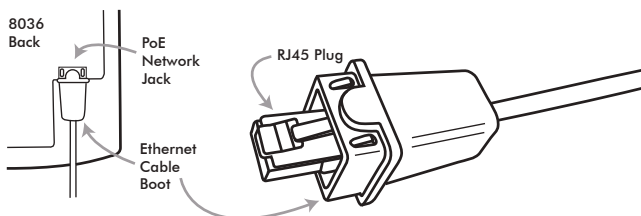

After inserting the plug into the 8036 jack, carefully position the boot into the jack cavity to prevent moisture or insects from getting inside.



*When inserting the plug into the jack, be sure the plug lock tab is not accidentally depressed, creating a loose connection.*

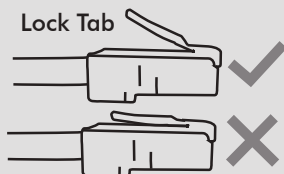

# Programming and Configuration

## Web Interface Control Panel

Primary configuration of the 8036 is through the web interface control panel. Here is where you will be able to set up your 8036 and also develop interface screens to create interactive applications.

## Accessing the Control Panel

To access the 8036 Control Panel, you first need to determine the 8036's IP address and then enter this address into a browser.

### *Find the IP Address*

After connecting the 8036 to a network PoE port, the 8036 will attempt to obtain an IP address from the DHCP server and display this on the screen.

**ALGO**  
Communication Solutions

## Welcome to the 8036 SIP Multimedia Intercom

To configure your new device, please open  
a web browser to the following address:

192.168.0.120



If this is the first time you are using the 8036 and no user interface has yet been set up, you will be displayed the Welcome screen to the right which provides the IP address. If a User Interface already exists, the IP address will be shown for a few seconds at boot time, before the splash screen appears.

You will need to know this IP address in order to access the web interface tool.

If the 8036 is unable to obtain an IP address from the DHCP server, it will default to the fixed IP address 192.168.1.111.

## Web Configuration Panel

Point your web browser to the 8036's IP address. This brings up the login page. The default password is **algo**.

The screenshot shows the web configuration panel for the Algo 8036. At the top, there is a dark header with the 'ALGO' logo on the left and 'Algo 8036 Control Panel' on the right. Below the header, a light gray box contains the text 'Welcome to the Algo 8036 SIP Multimedia Intercom Control Panel'. Underneath, it says 'Please enter your password.' There is a text input field labeled 'Password (default: algo)' with a masked password '....' and a 'Login' button with a right-pointing arrow. Below the login section, there is a 'Status' section with a dotted border. It contains three rows of status information: 'SIP Registration' is 'Successful', 'Call Status' is 'Idle', and 'Door Controller' is 'Network error (send)'.

<b>Welcome to the Algo 8036 SIP Multimedia Intercom Control Panel</b>	
Please enter your password.	
Password (default: <b>algo</b> )	<input type="password" value="...."/>
	<input type="button" value="Login"/>
<b>Status</b>	
SIP Registration	Successful
Call Status	Idle
Door Controller	Network error (send)

Once logged in, the Status page is shown which welcomes you to the program (see "Control Panel Menu Reference" on page 23). From here you can access all of the configuration options for your 8036 device.

## Setup SIP Account

The SIP account and related settings can all be found in the **Settings>SIP** section. This configuration will make the 8036's location known and allow the 8036 to make and receive calls. You must have a valid SIP account. You can get more details from your System/Network Administrator to fill in this section.

# Application Development

## Overview

With the 8036 you can easily design, implement, and update custom user interface screens and functions that help you communicate most effectively with visitors and guests. For example, you can make attractive landing pages with your company logo and graphics. On it, you can have buttons that make calls or that lead to various information or directory pages.

*Example 8036 Custom Graphics Screen using 3 x 3 Full Button layout with four active buttons*



You can set all of this up using the 8036 Control Panel. You'll also be able to back up all the configuration and user interface information to a PC for safekeeping.

## Creating User Interface Screens

The key to an effective implementation of the 8036 is to configure a package of interface screens that fulfill the various visitor functions you require. You do this easily through the **User Interface** menu in the 8036 Control Panel (see “User Interface” on page 43).

For a basic implementation, you can set up simple screens and pages using the generic button graphics and background screens provided with the system. You can also easily create graphics screens developed with standard image editing programs and then import them into the 8036. Either way, you can set up multiple pages with different button configurations and layouts, enable or disable specific button locations, and set different actions associated with each button.

You can also import tab-delimited text files containing names and numbers and have the 8036 display a directory whereby visitors can call individuals directly.

## Custom Graphic Screens

To develop custom interface screens you need to be able to create 640 x 480 pixel graphic files in the PNG (Portable Network Graphics) format. Most graphics/image editing programs (such as Adobe® Photoshop®) have this capability. Within the graphics program you can create your own background and button graphics and then align the button graphics (if used) to the layouts you have chosen for your 8036 User Interface.

The User Interface configuration allows you to create several types of pages with different button configurations. For information on the different types of button layout pages possible, please refer to the “Button Positioning Table” on page 59.

For example, here is a standard Two Button page layout in combination with a custom 640 x 480 PNG graphics file to create a simple Welcome page for visitors.



## **Directory (Addressbook) Listings**

You can also upload tab-delimited text files to allow the 8036 to display directory pages. You can then set up pages to use these directory files to display a call directory for visitors to use. For more information, see "Directory (Addressbook) Text Files" on page 59.

## **Uploading user content**

Before configuring a custom user interface, all the images, directory text files, and other resources that will be used by your UI must first be uploaded to the 8036.

You can upload individual files as you need them (see or you can upload content files in bulk using a properly formatted compressed file (in .tar.gz format). For more information on this, please see “Working with Compressed Files” on page 59.

# Control Panel Menu Reference

## Status

### Introduction

This screen provides a quick guide to setting up your 8036. It covers four key steps:

- SIP Configuration
- Network Settings
- Securing the 8036 with a Password
- Customer Registration with Algo

In addition, this screen provides the current status of the 8036 in regards to SIP Registration, Call activity, and Door Controller (if implemented) actions.

The screenshot shows the 'Status' tab selected in a navigation bar. The main content area is titled 'Welcome to the Algo 8036 SIP Multimedia Intercom Control Panel'. It contains a series of instructions for setting up the device, organized into five steps. At the bottom, there is a 'Status' section with a table showing the current state of various components.

**Status** Settings User Interface System Logout

### Welcome to the Algo 8036 SIP Multimedia Intercom Control Panel

Please take a minute to set up your SIP Multimedia Intercom:

**Step 1: Configure your SIP Multimedia Intercom**  
Use the SIP tab on the Settings page to set up the SIP connection information.

**Step 2: Design your touch screen user interface**  
Use the User Interface page to design the interactive application running on the touch screen.

**Step 3: Check network settings (Optional)**  
Use the Network tab on the Settings page to change network settings. The default setting for the SIP Multimedia Intercom is to obtain its IP address from a DHCP server. Contact your Network System Administrator if you plan to assign a static IP address, netmask, and gateway to the SIP Multimedia Intercom device.

**Step 4: Secure your SIP Multimedia Intercom (Optional)**  
Use the Admin tab on the Settings page to change the administrator password. Changing the password is extremely important if the 8036 is directly connected to a public network.

**Step 5: Register your SIP Multimedia Intercom (Optional)**  
Please register your product using the link below:  
<http://www.algosolutions.com/8036reg>  
Registration ensures your access to the latest upgrades to this product and important service notices.

**Status**

SIP Registration	No account
Call Status	Idle
Door Controller	Relay module not configured

# Settings

## SIP

Status Settings User Interface System Logout

SIP Mode Basic Control Network Performance Support Admin

### SIP Account

Here you can configure the SIP settings.

Basic Settings

SIP Domain (Proxy Server)	10.0.0.100 <small>(1) Default port is 5060. To specify a different port, enter PROXY-PORT, e.g. my_proxy:5075, or 193.168.1.10:5060.</small>
User (Extension)	1233
Authentication ID (Digest Username)	1233
Authentication Password (Digest Password)	****
Enable 3bound Call	<input type="checkbox"/>

Advanced Settings

Outbound Proxy	<small>(1) Default port is 5060. To specify a different port, enter OUTBOUND-PORT, e.g. my_outproxy.com:5075, or 193.168.1.10:5060.</small>
STUN Server	
Register Period	3600
Keep-alive Method	None
Request Media Bandwidth	<input checked="" type="radio"/> Enabled <input type="radio"/> Disabled
Play Ringback Tone	<input type="radio"/> Enabled <input checked="" type="radio"/> Disabled
Outbound Ring Limit	5 rings <small>(1) 1 ring = 6 seconds</small>

Server Redundancy

Enable Server Redundancy Feature (Multiple SIP Server Support)	<input checked="" type="radio"/> Enabled <input type="radio"/> Disabled
Backup Server # 1	
Backup Server # 2	
Poling Interval	120 seconds (2 minutes) <small>(1) Time period between sending monitoring packets to each server. For active servers are always polled, and active server may optionally be polled (see below).</small>
Pol Active Server	<input type="radio"/> Enabled <input checked="" type="radio"/> Disabled
Automatic fallback	<input checked="" type="radio"/> Enabled <input type="radio"/> Disabled <small>(1) Explicitly poll current server to monitor availability. May also be loaded automatically by other regular events, so can be disabled to reduce network traffic.</small>
Poling Method	<input checked="" type="radio"/> SIP NOTIFY <input type="radio"/> SIP OPTIONS <small>(1) SIP message used to poll servers to monitor availability.</small>

Save

### Basic Settings

**SIP Domain  
(Proxy Server)**

SIP Server Name or IP address

**User (Extension)**

Used to register the device on the SIP Server.



<b>Authentication ID (Digest Username)</b>	Used to register the device on the SIP Server.
<b>Authentication Password (Digest Password)</b>	Used to register the device on the SIP Server.
<b>Enable Inbound Call</b>	Allows the 8036 device to auto answer an inbound call. By default, this functionality is not activated.
<b>Advanced Settings</b>	
<b>Outbound Proxy</b>	Outbound proxy is a proxy (server) that stands between a private network and the Internet. Default port is 5060.
<b>STUN Server</b>	Allow communication between SIP server and 8036 if NAT is present.
<b>Register Period</b>	Maximum requested period of time where the 8036 will re-register with the SIP server. Default setting is 3600 seconds (1 hour). Only change if instructed otherwise.
<b>Keep-alive Method</b>	Method to maintain connection between the 8036 and the SIP server if the 8036 is behind NAT. Choices are: <ul style="list-style-type: none"> <li>• None</li> <li>• Double CRLF</li> </ul>
<b>Request Media Bandwidth</b>	Enable or disable.
<b>Play Ringback Tone</b>	**Coming Soon** Allow audible ringback tone to be played on the 8036 speaker until the call is answered.

<b>Outbound Ring Limit</b>	Typically set to ensure that a call will not reach voicemail. This feature can be used to set a limit on how long the speaker will ring before timing out.
<b>Enable Server Redundancy Feature</b>	Two secondary SIP servers may be configured. The 8036 Multimedia Intercom will attempt to register with the primary server but switch to a secondary server when necessary. The configuration allows re-registration to the primary server upon availability or to stay with a server until unresponsive. If Server Redundancy is selected the web page will expand as shown.
<b>Backup Server #1</b>	If primary server is unreachable the 8036 Multimedia Intercom will attempt to register with the backup servers. If enabled, the 8036 Multimedia Intercom will always attempt to register with the highest priority server.
<b>Backup Server #2</b>	If backup server #1 is unreachable the 8036 Multimedia Intercom will attempt to register with the 2nd backup server. If enabled, the 8036 Multimedia Intercom will always attempt to register with the highest priority server.
<b>Polling Interval</b>	Time period between sending monitoring packets to each server. Non-active servers are always polled, and active server may optionally be polled (see below).

<b>Poll Active Server</b>	Explicitly poll current server to monitor availability. May also be handled automatically by other regular events, so can be disabled to reduce network traffic.
<b>Automatic Fallback</b>	Reconnect with higher priority server once available, even if backup connection is still fine.
<b>Polling Method</b>	SIP message used to poll servers to monitor availability.

# Media

Status Settings User Interface System Logout

SIP **Media** Door Control Network Provisioning Snapshot Admin

## Media

Here you can configure the media settings.

### Video

Video Mode	Two-way Video
H.264 Video Profile Level	Level 3 Baseline Profile
H.264 Packet Type	Single NAL Unit
Enable Web Video	Disabled
Enable Auto White Balance	<input checked="" type="checkbox"/>
Video Quality Control Method	<input checked="" type="radio"/> Constant Bitrate <input type="radio"/> Constant Quality
Maximum Video Bandwidth	1 mbps
QP Min	20
QP Max	31
Powerline Frequency	60 Hz (eg. North America)

### Audio

Enable G.722 Codec	<input checked="" type="checkbox"/>
UI Volume (i.e. click sound, ringback tone etc.)	6
Speaker Volume	8
Microphone Volume	High

 Save

## Video

### Video Mode

- **One-way Video (outgoing only):** The 8036 only sends video to the remote end (eg. a video phone). It does not show any video on the 8036 itself. Two-way audio is still maintained in this configuration.
- **Two-way Video:** Video communication in both directions if remote end supports video.



Note that video is only sent when the device is active on a call.

<b>H.264 Video Profile Level</b>	<ul style="list-style-type: none"><li>• Level 1.3 Baseline Profile</li><li>• Level 3 Baseline Profile</li></ul>
<b>H.264 Packet Type</b>	<ul style="list-style-type: none"><li>• Single NAL Unit</li><li>• Fragmentation Unit Type A (FU-A)</li></ul>
<b>Enable Web Video</b>	<p>This mode directs the 8036 video to the 8036 Control Panel web interface in two different sizes (CIF 352X288 or VGA 640x480). When it is disabled, neither the 8036 nor the remote SIP client show video. This is true even if the remote end is video-capable. Using this mode, video can only be seen in the web interface, and only when there is a call in progress.</p> <p>Once web video is enabled, the video can be seen at either:</p> <ul style="list-style-type: none"><li>• &lt;ip address&gt;/video</li><li>• &lt;ip address&gt;:8080</li></ul>
<b>Enable Auto White Balance</b>	Enable or disable Auto White Balance.
<b>Video Quality Control Method</b>	<ul style="list-style-type: none"><li>• <b>Constant Bitrate:</b> Allows modification of video parameters at constant bitrate: Maximum Video Bandwidth, QP Min, and QP Max.</li><li>• <b>Constant Quality:</b> Allows PQ value (default: 28) modification, given constant video quality.</li></ul>

<b>Maximum Video Bandwidth</b>	Set a signal capacity for video content transmission.
<b>QP Min</b>	Minimum Quantization Parameter for H.264 level. (Default: 20)
<b>QP Max</b>	Maximum Quantization Parameter for H.264 level. (Default: 31)
<b>Powerline Frequency</b>	<ul style="list-style-type: none"> <li>• 60 Hz (e.g. North America)</li> <li>• 50 Hz (e.g. Europe)</li> </ul>
<b>Audio</b>	
<b>Enable G.722 codec</b>	Enable or disable G.722 codec
<b>UI Volume</b>	The 8036 provides click sounds to provide users with audible feedback to assure them their key presses were registered. The click sound is played, if enabled, when the door is open. You can adjust the sound volume for these feedback sounds from Mute to 10 (loudest).
<b>Speaker Volume</b>	From 1 (lowest) to 10 (highest)
<b>Microphone Volume</b>	Low, Medium, High

## Door Control

The 8036 can be used with the optional 8061 SIP Relay Module to provide door control functionality. This section allows you configure the 8061 SIP Relay Module settings (if used).

Settings | User Interface | System | Logout

SIP | Media | **Door Control** | Network | Provisioning | Snapshot | Admin

### Door Relay Settings

Here you can configure the door relay module settings.

**Door Controller 1**

Relay Module Address	172.16.1.94 <small>(i) IPv4 Address</small>
Relay Module Password	****
Momentary Open Code	31 <small>(i) DTMF max 4 digits</small>
Momentary Open Duration	3 Seconds

**Door Controller 2**

Relay Module Address	172.16.1.94 <small>(i) IPv4 Address</small>
Relay Module Password	****
Momentary Open Code	32 <small>(i) DTMF max 4 digits</small>
Momentary Open Duration	30 Seconds

**Door Controller 3**

Relay Module Address	172.16.1.96 <small>(i) IPv4 Address</small>
Relay Module Password	****
Momentary Open Code	33 <small>(i) DTMF max 4 digits</small>
Momentary Open Duration	3 Seconds

**Door Controller 4**

Relay Module Address	172.16.1.97 <small>(i) IPv4 Address</small>
Relay Module Password	****
Momentary Open Code	34 <small>(i) DTMF max 4 digits</small>
Momentary Open Duration	3 Seconds

Save

<b>Relay Module Address</b>	IP address of 8061 SIP Relay Module
<b>Relay Module Password</b>	Used to authenticate the link between the 8036 and the 8061. Default password is <b>algo</b>
<b>Momentary Open Code</b>	1-4 digit DTMF code that can be used to unlock the door for a brief period of time. Leave this field blank to disable this feature. (Default: 6)
<b>Momentary Open Duration</b>	The duration for which to unlock the door when the Momentary Open Code is entered. From 1/4 to 30 seconds.

For more information on Door Control configuration and setup, see “Door Control” on page 57.



## Network

Status Settings User Interface System Logout

SIP Media Door Control **Network** Provisioning Snapshot Admin

### Network Interface

Here you can configure the network interface settings.

**Ethernet**

Protocol

IP Address

Netmask

Gateway

DNS Server 1

DNS Server 2

**Virtual LAN**

Enable VLAN

VLAN ID   
Value range: 0 to 4094

VLAN Priority   
Value range: 0 to 7

 Save

### Ethernet

#### Protocol

- DHCP Client (default)
- Static Address

The default DHCP Client setting will allow the DHCP server to automatically configure IP addresses for each 8036 on the network. Alternatively, if your IT Administrator has assigned one or more *static* IP addresses, set the Protocol setting to **Static Address**.

<b>Virtual LAN</b>	
<b>Enable VLAN</b>	<p>Enable or disable VLAN Tagging. VLAN Tagging is the networking standard that supports Virtual LANs (VLANs) on an Ethernet network. The standard defines a system of VLAN tagging for Ethernet frames and the accompanying procedures to be used by bridges and switches in handling such frames. The standard also provides provisions for a quality of service prioritization scheme commonly known as IEEE 802.1p and defines the Generic Attribute Registration Protocol.</p>
<b>VLAN ID</b>	<p>Specifies the VLAN to which the Ethernet frame belongs. A 12-bit field specifying the VLAN to which the Ethernet frame belongs. The hexadecimal values of 0x000 and 0xFFF are reserved. All other values may be used as VLAN identifiers, allowing up to 4094 VLANs. The reserved value 0x000 indicates that the frame does not belong to any VLAN; in this case, the 802.1Q tag specifies only a priority and is referred to as a priority tag. On bridges, VLAN 1 (the default VLAN ID) is often reserved for a management VLAN; this is vendor specific.</p>

<b>VLAN Priority</b>	Sets the frame priority level. Otherwise known as Priority Code Point (PCP), VLAN Priority is a 3-bit field which refers to the IEEE 802.1p priority. It indicates the frame priority level. Values are from 0 (lowest) to 7 (highest).
----------------------	---

## Provisioning

The screenshot shows a web interface for configuring provisioning settings. At the top, there are navigation tabs: Status, Settings (selected), User Interface, System, and Logout. Below these are sub-tabs: SIP, Media, Door Control, Network, Provisioning (selected), Snapshot, and Admin. The main heading is "Provisioning Settings". Below the heading is a brief instruction: "Here you can configure settings for provisioning function." The settings are grouped under a "Settings" section and include:

- Provisioning Mode:  Enabled  Disabled
- Server Method:  DHCP Option 66  Static
- Static Server: [Text input field]
- Download Method:  TFTP  FTP  HTTP
- Auth User Name: [Text input field]
- Auth Password: [Text input field]
- Config Download Path: [Text input field]
- Firmware Download Path: [Text input field]

At the bottom right of the settings area, there is a green checkmark icon and the text "Save".

Provisioning allows installers to pre-configure 8036 Multimedia Intercom units prior to installation on a network. It is typically used for large deployments to save time and ensure consistent setups.

There are two different Provisioning methods that can be used: via DHCP Option 66 or via a Static Server. In addition, there are three different ways to download provisioning files from a "Provisioning Server": TFTP (Trivial File Transfer Protocol), FTP, or HTTP.

For example, 8036 Multimedia Intercom configuration files can be automatically downloaded from a TFTP server using DHCP Option 66. This option code (when set) supplies a TFTP boot server address to the DHCP client to boot from.

DHCP must be enabled if using DHCP Option 66, in order for Provisioning to work.

One of two files can be uploaded on the Provisioning Server (for access via TFTP, FTP, or HTTP):

Generic (for all 8036 Multimedia Intercoms)	algop8036.conf
Specific (for a specific MAC address)	algom[MAC].conf

### **MD5 Checksum**

In addition to the .conf file, an .md5 checksum file must also be uploaded to the Provisioning server. This checksum file is used to verify that the .conf file is transferred correctly without error.

A tool such as can be found at the website address below may be used to generate this file:

<http://www.fourmilab.ch/md5>

The application doesn't need an installation. To use the tool, simply unzip and run the application (md5) from a command prompt. The proper .md5 file will be generated in the same directory.

If using the above tool, be sure to use the "-l" parameter to generate lower case letters.

## ***Generating a generic configuration file***

1. Connect 8036 to the network
2. Access the 8036 Web Interface Control Panel
3. Configure the 8036 with desired options
4. Click on the System tab and then Maintenance.
5. Click "Backup" to download the current configuration file
6. Save the file settings.txt
7. Rename file settings.txt to algop8036.conf
8. File algop8036.conf can now be uploaded onto the Provisioning server

If using a generic configuration file, extensions and credentials have to be entered manually once the 8036 Multimedia Intercom has automatically downloaded the configuration file.

# Snapshot

Status Settings User Interface System Logout

SIP Media Door Control Network Provisioning **Snapshot** Admin

## Snapshot Settings

Here you can configure settings for snapshot feature

**Settings**

Enable snapshot feature  Enabled  Disabled

**Capture Criteria**

One of these needs to be enabled to capture snapshots

Trigger on motion event  Enabled  Disabled

Trigger on call event  Enabled  Disabled

**Image Capture Parameters**

Archiving fps: 3 FPS  
The frame rate at which device will logs events

Number of images before the event: No image before the event  
Capture this number of images before the event

Number of images after the event: 2  
Capture this number of images after the event

Minimum time between events: 30 seconds  
Will ignore any events within this time of previous event

**Image Upload**

Email  Enabled  Disabled

Email Host

Sender Email

Sender Email Password

Email Recipients(To)

FTP Upload  Enabled  Disabled

FTP Host

FTP Port: 21

FTP Upload Directory: /

FTP Username

FTP Password

Maximum time to archive an event: 1 min  
Cancel an archiving event if not done within this time

 Save

<b>Settings</b>	
<b>Enable snapshot feature</b>	Allow for snapshots to be captured when motion is detected and/or a call is made.
<b>Capture Criteria</b>	
<b>Trigger on motion event</b>	Allow for snapshots to be taken when movement is detected.
<b>Trigger on call event</b>	Allow for snapshots to be taken when an intercom call is made from the 8036.
<b>Image Capture Parameters</b>	
<b>Archiving fps</b>	Set the frame rate at which the 8036 will capture images.
<b>Number of images before the event</b>	Set the number of images to be captured before the above event.
<b>Number of images after the event</b>	Set the number of images to be captured after the above event.
<b>Minimum time between events</b>	Set the time interval during which additional events will be ignored after the first one.
<b>Image Upload</b>	
<b>Email</b>	<b>**Coming Soon**</b>
<b>FTP Upload</b>	<b>**Coming Soon**</b>
<b>Maximum time to archive an event</b>	Set a limit when event archiving should stop if it hasn't done so before timing out.



# Admin

Status Settings User Interface System Logout

SIP Media Door Control Network Provisioning Snapshot Admin

## Admin

Here you can configure the admin settings.

**Admin Password**

Password

Confirmation

**General**

Device Name (Hostname) 8036

NTP Time Server pool.ntp.org

Device Time (UTC) Fri Mar 11 00:00:38 2016 [Sync with browser](#)

**Services**

Enable Network UI Agent

**Log settings**

Log Level Info (Medium)

Log Size ( 1 ~ 100 kB ) 100

Log Method Local

 Save

## Admin Password

### Password / Confirmation

Password to log into the 8036 web interface Control Panel. You should change the default password as soon as possible in order to secure the device on the network.



*If you have changed your password but forgotten it, you can reset your password through a Soft Reset of your 8036. See "Soft Reset" on page 59.*

<b>General</b>	
<b>Device Name (Hostname)</b>	Name to identify the device.
<b>NTP Time Server</b>	Domain name or IP address of NTP time server. Default is pool.ntp.org
<b>Device Time (UTC)</b>	If the NTP Time Server above is not available, you can sync time with your browser. Note that this will be UTC time and will likely be different than your local time indication.
<b>Services</b>	
<b>Enable Network UI Agent</b>	Enable or disable network UI Agent.
<b>Log Settings</b>	
<b>Log Level</b>	Amount of information provided in the log files. Choices are: <ul style="list-style-type: none"> <li>• Error (Low)</li> <li>• Info (Medium)</li> <li>• Debug (High)</li> </ul>
<b>Log Size</b>	Maximum size of log file in KB. Default is 100 KB.
<b>Log Method</b>	<ul style="list-style-type: none"> <li>• Local</li> <li>• Network</li> <li>• Both Local and Network</li> </ul>

## User Interface

In this section, you can quickly create user interface screens using standard graphic files that come with your 8036. You can also create a UI using custom images (created with 3rd party tools like Adobe Photoshop) that you upload to the 8036. This can be done from the **Upload Image, Addressbook or Sound files** section (see “Select the file” on page 49) or by uploading a tar.gz file to the device (see “Uploading user content” on page 22).



*If you want to use custom graphics for your user interface, all the images, directory text files, and other resources that will be used by this interface must first be uploaded to the device.*

### Create Pages

Number of Pages to Create:  Page limit is 10, created or fail.  
 Page Type:  Button  Directory

### Page Settings

Start Page:  Use startpage starts with the page.  
 Page timeout:  Maximum time for any page.  
 Page timeout action:  One of the will happen when a page times out.  
 Motion sensor:  Enable is, detection will stop, screen brightness codes back to normal from a dimmed state.  
 Motion sensor behaviour during slide show:   
 Default LCD brightness:   
 Dim LCD at timeout:  Enable  Disable  
 Door unlock Code:   
 Door unlock Code 2:   
 Door unlock Code 3:   
 Door unlock Code 4:   
 Play click sound when door is unlocked:  Enable  Disable  
 Display a message when door is open using DTMF:  Enable  Disable  
 Show hangup button during call:  Show  Hide  
 End call action:  Applies to all the calls to/from the unit.

### User Interface Themes

Install New Theme:  No file selected.   
 Select a Theme:

### SlideShows

Upload New Slide:  No file selected.

### Upload Image, Addressbook or Second File

Select File:  No file selected.   
[Addressbook format](#)

### List of Pages

- Page 1 -
- Page 2 - Call\_English
- Page 3 - Call\_French

## Create Pages

This is the section where you can create new user interface pages.



The screenshot shows a web-based configuration interface titled "Create Pages". It contains the following elements:

- A field labeled "Number of Pages to Create" with a dropdown menu set to "1". Below it is a note: "Page limit is 20. Created so far: 3".
- A "Page Type" section with two radio buttons: "Button" (which is selected) and "Directory".
- An "Add Page(s)" button at the bottom.

Two types of pages are able to be created:

- **Pages with buttons**

Pages where one or more buttons are displayed in accordance with pre-defined configurations. The buttons can provide different functionality such as making a call or redirecting to another page.

- **Directory Pages**

A list of names (sourced from an uploaded tab-delimited text file) with the ability to call people's phone numbers by selecting the name, then pressing **Call**.



Example Button and Directory pages

<b>Number of pages to be created</b>	Sets the number of pages that will become individually editable using the List of Pages section.
<b>Page Type</b>	<ul style="list-style-type: none"> <li>• Button</li> <li>• Directory</li> </ul>

## Page Settings

This section allows you to change settings that will be reflected throughout the user interface. Once the page settings are configured, press 'Save Changes' to restart the user interface and apply the changes.

### Page Settings

Start Page	<input type="text" value="page1"/> ⓘ User interface starts with this page
Page timeout	<input type="text" value="Never"/> ⓘ Maximum idle time for any page
Page timeout action	<input type="text" value="Do Nothing"/> ⓘ One of this will happen when a page times out
Motion Sensor	<input type="text" value="Enable"/> ⓘ i.e. Slideshow will stop, screen brightness comes back to normal from a dimmed state
Motion sensor behaviour during slide show	<input type="text" value="Exit slideshow"/>
Default LCD brightness	<input type="text" value="50"/>
Dim LCD at timeout	<input type="radio"/> Enable <input checked="" type="radio"/> Disable
Door Unlock Code	<input type="text"/>
Door Unlock Code 2	<input type="text"/>
Door Unlock Code 3	<input type="text"/>
Door Unlock Code 4	<input type="text"/>

<b>Start Page</b>	Sets the page to display when the 8036 starts up.
<b>Timeout time</b>	Sets the maximum idle time for any page. Selectable value from 1 second to 1 hour.
<b>Timeout Action</b>	Sets the action to take when the timeout time has elapsed. Options are: <ul style="list-style-type: none"> <li>• Do Nothing</li> <li>• Go to Homepage</li> </ul>
<b>Motion Sensor</b>	Enable or disable the motion sensor. When enabled, motion can be configured to trigger events like snapshots, stopping slideshows, and increasing screen brightness.
<b>Motion sensor behaviour during slide show</b>	Sets the action to take when motion is detected. Options are: <ul style="list-style-type: none"> <li>• Do Nothing</li> <li>• Exit slideshow</li> <li>• Exit slideshow and make call</li> </ul>
<b>Default LCD brightness</b>	Set default LCD screen brightness. From 1 (lowest) to 100 (highest)
<b>Dim LCD at timeout</b>	Enable or disable LCD screen dimming after timeout.
<b>Door Unlock Code (1 - 4)</b>	1-8 digit numeric code that can be used, from the touch screen, to unlock the door for a brief period of time. Typically used as an employee access code.  Up to 4 different Door Unlock Codes can be configured. For more information, see "Door Control" on page 57.

<b>Play click sound when door is unlocked</b>	Enable or disable a click sound to be played when a door is unlocked, for awareness.
<b>Display a message when door is open using DTMF</b>	Enable or disable a message to be displayed when the door is opened via DTMF.
<b>Show hangup button during call</b>	A hangup button can be displayed on the 8036 while a call is in progress. This option allows you to show or hide this button.
<b>End call action</b>	Sets the action to take when any call to/from the 8036 unit ends. Options are: <ul style="list-style-type: none"> <li>• Do Nothing</li> <li>• Go to Previous Page</li> <li>• Go to Homepage</li> </ul>
<b><i>User Interface Themes</i></b>	
<b>Install New Theme</b>	Upload a custom theme to display on the 8036 user interface.
<b>Select a Theme</b>	Select a pre-installed theme to display on the 8036 user interface.
<b><i>Slideshow</i></b>	
<b>Upload New Slides</b>	A slideshow can play on the 8036 while it is not used. The custom slides/images for the slideshow can be uploaded here.



## Upload Image, Addressbook or Sound files

### Select File

Allows you to upload a PNG image file or a tab-delimited text file (.TXT) to the device. The image file will be available for use in page backgrounds (see “Custom Graphic Screens” on page 20).

The text file will be available to act as the source for Directory listings, such as a staff contact list (see “Directory (Addressbook) Text Files” on page 59).

## List of Pages

This section allows you to modify and configure the various pages within your application and the actions associated with various page-specific buttons and user actions.

Click on the Page Title Text (e.g. “Page 1”) or the “+” sign in front of each page to view these settings for each page.

### List of pages

Page 1 - First UI Page

Page Description: First UI Page

Background Image: default1-sky-clouds.png

Button Configuration: Single Button

Back Button: Enable/Disable

Home Button: Enable/Disable

When touched outside button(s): Do Nothing

Button 1

Enable/Disable

Button Text: Make a Call

Action: Call

Dialing Extension: 1234

Save This Page

Delete this page

Save All Pages

Save All Pages

### Page Description

Adding a clear description of the page will make finding and editing pages later easier, particularly if there are many of them.

<b>Background Image</b>	<p>Allows setting a background image for the screen. Several standard options have been supplied. The choices displayed depend on how many PNG files have been uploaded to the 8036's memory.</p>
<b>Button Configuration</b>	<p>A button configuration is a defined layout of buttons on the 640 x 480 screen. Several different button configurations have been provided:</p> <ul style="list-style-type: none"> <li>• Single Button</li> <li>• Two Buttons</li> <li>• Three Buttons</li> <li>• 2 x 2 Buttons</li> <li>• 3 x 2 Buttons</li> <li>• 3 x 3 Buttons</li> <li>• 3 x 3 Buttons Full</li> </ul> <p>For detailed information on exact button positions, including layout thumbnails, please view the "Button Positioning Table" on page 59.</p>
<b>Back Button</b>	<p>Adds a Back button to the lower left of the screen. Clicking it will return the user to the previously displayed screen. The Back button can be enabled or disabled.</p>
<b>Home Button</b>	<p>Adds a Home button to the lower right of the screen. Clicking it will return the user to the Home Screen (Page 1). The Home button can be enabled or disabled.</p>

<b>When touched outside button</b>	Sets an action and result when a visitor touches the screen where there is no display button. The three types of actions are <b>Call</b> , <b>Goto</b> , and <b>Do Nothing</b> , each selectable through a drop down box.
<b>Call</b>	When selected, an Extension field is displayed where you can enter the telephone extension that should be called.
<b>Goto Page</b>	<p>When selected, a Target Page dropdown box is displayed allowing you to select which page to display. In addition to the pages that you have created, the following pages are available:</p> <p><b>Dial Keypad:</b> A dialpad page is presented, complete with a <b>Call</b> button (see “Dial Keypad” on page 52). This allows the user to dial a phone number.</p> <p><b>Door Access Keypad:</b> A dialpad page is presented, similar to the Dial Keypad above, except that a <b>Call</b> button is used instead of an <b>Submit</b> button. This allows the user to enter a <b>Door Unlock Code</b> (see “Page Settings” on page 46). Up to 4 different Door Access Keypads are available. For examples, see “Door Control” on page 57.</p>
<b>Do Nothing</b>	Sets the device to ignore any touches to the screen outside of a button.

### **Button Settings**

<b>Enable / Disable</b>	Turns the button functionality on or off for the location indicated.
-------------------------	--

<b>Button Text</b>	Sets the text to be displayed in the button location.
<b>Action Type</b>	<ul style="list-style-type: none"> <li>• Goto</li> <li>• Call</li> <li>• Do Nothing</li> </ul>
<b>Target Page</b>	This setting is displayed if <b>Action Type</b> is set to <b>Goto</b> . Sets the page to display after button is clicked. Dropdown box displays all available pages.
<b>Dialing Extension</b>	This setting is displayed if <b>Action Type</b> is set to <b>Call</b> . Enter the telephone extension that should be called when the button is clicked.

Dial Keypad

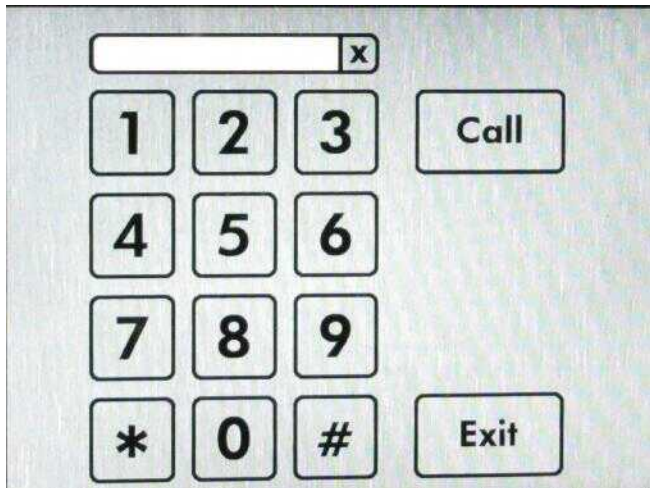

# System Maintenance

Status	Settings	User Interface	<b>System</b>	Logout
<b>Maintenance</b> System Log   Journal Log   About				
<b>System Maintenance</b>				
<b>Backup / Restore Configuration</b>				
Click "Generate configuration archive" to download an archive of the current configuration files. To reset configuration, click "Perform Reset".				
Download Configuration Backup	<a href="#">Generate Configuration Archive</a>			
Reset Configuration to Defaults	<a href="#">Perform reset</a>			
To restore configuration files, you can upload a previously generated backup archive here.				
Restore Configuration Backup	<a href="#">Browse...</a>	No file selected	<a href="#">Upload archive...</a>	
<b>Default User Interface</b>				
Click "Generate user interface archive" to download an archive of the current User Interface. To erase the User Interface, click "Erase".				
Download User Interface Backup	<a href="#">Generate User Interface Archive</a>			
Erase	<a href="#">Erase</a>			
To restore user interface files, you can upload a previously generated backup archive here. Click "upgrade user interface" to use the latest default user interface.				
Restore User Interface Backup	<a href="#">Browse...</a>	No file selected	<a href="#">Upload Archive...</a>	
Upgrade User Interface	<a href="#">Upgrade User Interface</a>			
<b>Custom User Interface</b>				
Install Custom Application	<a href="#">Browse...</a>	No file selected	<a href="#">Upload Custom Application</a>	
Select User Interface	<input type="text" value="userp"/>			
	<a href="#">Set as Active Application</a>			
	<a href="#">Delete Application</a>			
	<a href="#">Download Application</a>			
<b>Reboot</b>				
Click "Reboot" to reboot the device.				
Reboot	<a href="#">Reboot</a>			
<b>Upgrade to New Firmware (by uploading)</b>				
Upload a new firmware image and corresponding signature here to upgrade the device.				
Firmware Image	<a href="#">Browse...</a>	No file selected	<input type="text"/>	
Signature	<a href="#">Browse...</a>	No file selected	<input type="text"/>	
Upgrade	<a href="#">Upgrade...</a>			
<b>Upgrade to New Firmware from URL</b>				
Provide the path of new firmware image and corresponding signature here to upgrade the device.				
Firmware Image URL	<input type="text"/>			
Signature URL	<input type="text"/>			
	<a href="#">Upgrade from URL...</a>			

## **Backup / Restore Configuration**

<b>Download Configuration Backup</b>	Creates a backup .tar.gz file of configuration settings for download. The configuration backup contains UI settings and SIP settings.
<b>Reset Configuration to Defaults</b>	Discards current configuration and resets to original factory settings.
<b>Restore Configuration Backup</b>	To restore configuration settings, point to an archived configuration .tar.gz file, then click Upload Archive. The 8036 will restart with the new settings.

## **Backup / Restore User Interface**

In this section, you can make a backup copy of (archive) all user interface (UI) files, erase all UI files, or restore the UI from an archive file.

<b>Download User Interface Backup</b>	Click <b>Generate UI archive</b> to download a compressed file (in .tar.gz format) containing all UI settings and files, including images and addressbook text files. Note that the files will have a folder structure where different files will be separated into different folders. It is important to maintain this folder structure to permit restoring later.
<b>Erase</b>	Click <b>Erase</b> to delete all UI files from the 8036. Before using this function, we suggest making a backup first (see above), just in case!

<b>Restore User Interface Backup</b>	<p>Click <b>Browse</b> to select a compressed file containing all user interface images and text files. Then click <b>Upload archive</b> to load the file to the 8036.</p> <p>Once the compressed file is uploaded, the 8036 automatically extracts the files. Note that a single file or partial group of files can also be uploaded, as long as they maintain the required folder structure and are zipped in that structure. The 8036 may take several minutes to complete the update.</p>
<b>Upgrade User Interface</b>	<p>To restore to the latest default user interface.</p>
<b>Custom User Interface</b>	
<b>Install Custom Application</b>	<p>Click <b>Browse</b> to select a compressed file containing custom user interface files. Then click <b>Upload Custom Application</b> to load the files to the 8036.</p>
<b>Select User Interface</b>	<p>Select user interface to display on the 8036 screen.</p>
<b>Reboot</b>	<p>Reboots the device.</p>
<b>Upgrade to New Firmware</b>	
<p>This section allows you to upload a new firmware image and corresponding checksum to upgrade the device. For more information, please see "Upgrade 8036 Firmware" on page 59.</p>	

## System Log

For Algo Technical Support use only.

## ***Kernel Log***

For Algo Technical Support use only.

## ***About***

Provides basic product information, Algo contact information, and credits.



# Door Control

The 8036 can provide door control functionality when used with the optional Algo 8061 SIP Relay Module.

The 8061 serves as a bridge between the 8036 and peripheral hardware such as door strikes, door sensors, door bells, etc.

As a door opening controller, the 8061 can be located in a secure environment to prevent tampering by outside visitors.

The door control feature is activated by a command from the answering telephone keypad, or entry of the door release code by a visitor.

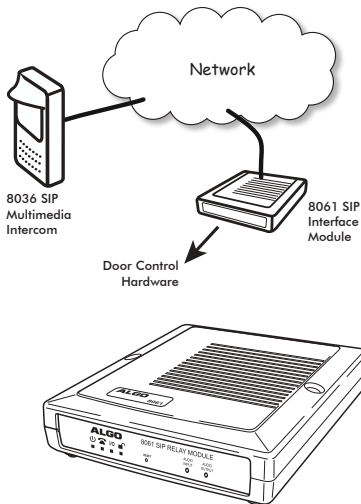

## *PoE and Relay Connections on back of 8061 SIP Relay Module*

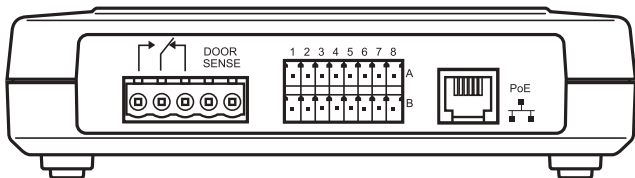

## Configuring the 8061

1. Find the IP address of the Algo 8061 using the Algo locator tool available from the Algo website ([www.algosolutions.com/Locator](http://www.algosolutions.com/Locator)). This tool displays all of the Algo devices available on the network, and their corresponding IP addresses. Note this address down as you will need it when you configure the 8036 for use with this device.
2. Point your browser to the above IP address. The 8061 Control Panel will be displayed.
3. Log in. The default password is **algo**
4. Go to the **Config** page and set a password in the Door Control Password field in the **Features** section. Note this password down as you will be reusing it when configuring the 8036 with this device.

The screenshot shows the 'Features' configuration page. It contains several settings:

Multicast Zone	224.0.2.60:50000	Door Control Link	<input checked="" type="radio"/> Enabled <input type="radio"/> Disabled
Remote Tone	1202.wav	Door Control Password	*****
Multicast from Analog Input	<input type="radio"/> Enabled <input checked="" type="radio"/> Disabled		

5. To open a door, the 8036 sends a message to the 8061's IP address (not extension). To receive the message, enable the 8061 **Door Control Link** and configure a **Door Control Password**:

The screenshot shows the 'Door Relay Settings' page. It includes a navigation bar with 'Status', 'Basic Settings', 'Advanced Settings', 'System', and 'Logout'. Below the navigation bar, there are tabs for 'SEP', 'CallBox', 'Events', and 'Door Control'. The 'Door Control' tab is active, showing the following settings:

**Door Relay Settings**  
Here you can configure door relay settings.

**Door Relay**

Door Control Link	<input checked="" type="radio"/> Enabled <input type="radio"/> Disabled
Door Control Password	1234

## Configuring the 8036 with the 8061

1. Open the 8036 web interface Control Panel.
2. Go to **Settings > Door Control** and, in the **Relay Module Address** field, enter the IP address of the 8061 you determined in the previous section.
3. Enter the **Relay Module Password** that you set previously when you configured the 8061.



*Note that the Relay Module Password is used solely to secure the link between the 8036 and the 8061. It is not the same as the Door Unlock code.*

4. Refer to “Door Control” on page 31 for more configuration options.



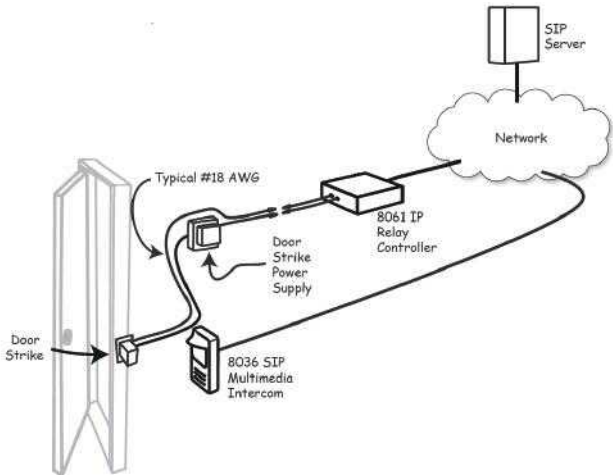

## Door Control Hardware and Wiring

*Typical 8036 / 8061 Door Control Setup*



## Door Relay Examples

When a call is established with the 8036 (**Intercom-to-Phone** or **Phone-to-Intercom**) the person on the phone can open the door by entering a code on the telephone (DTMF). Below are some sample 8036 configurations (in **Settings > Door Control**) for door-open codes.

Door Relay Settings	
Here you can configure the door relay module settings.	
<b>Door Controller 1</b>	
Relay Module Address	172.16.1.94 <small>(i) IPv4 Address</small>
Relay Module Password	**** 
Momentary Open Code	31 <small>(i) DTMF max 4 digits</small>
Momentary Open Duration	3 Seconds ▾
<b>Door Controller 2</b>	
Relay Module Address	172.16.1.94 <small>(i) IPv4 Address</small>
Relay Module Password	**** 
Momentary Open Code	32 <small>(i) DTMF max 4 digits</small>
Momentary Open Duration	30 Seconds ▾
<b>Door Controller 3</b>	
Relay Module Address	172.16.1.96 <small>(i) IPv4 Address</small>
Relay Module Password	**** 
Momentary Open Code	33 <small>(i) DTMF max 4 digits</small>
Momentary Open Duration	3 Seconds ▾
<b>Door Controller 4</b>	
Relay Module Address	172.16.1.97 <small>(i) IPv4 Address</small>
Relay Module Password	**** 
Momentary Open Code	34 <small>(i) DTMF max 4 digits</small>
Momentary Open Duration	3 Seconds ▾

## Opening the Door for Varying Lengths of Time

In the above 8036 screen shot, **Door Controller 1** and **2** both work with the same 8061 (same IP and password), but **Momentary Open Code 31** (DTMF 31) is configured to open the door for 3 seconds (**Momentary Open Duration**), while DTMF 32 is configured to open the same door for 30 seconds.



The “Momentary Open Codes” (DTMF) can only grant entry when dialed on the phone during a call with the 8036. These codes are not the same as the “Door Unlock Codes” entered on the 8036 screen keypad.

## Configuring Multiple Keypads

The 8036 has 4 **Dial Keypads**. Each keypad can be configured with an associated **Door Unlock Code** (in **Page Settings** of the **User Interface** tab). These 4 **Door Unlock Codes** will open the door based on the corresponding settings of the 4 **Door Controllers** in **Settings > Door Control**.

Page Settings	
Start Page	page1 <small>① User interface starts with this page</small>
Page timeout	Never <small>① Maximum idle time for any page</small>
Page timeout action	Do Nothing <small>① One of this will happen when a page times out</small>
Motion Sensor	Enable <small>① i.e. Slideshow will stop, screen brightness comes back to normal from a dimmed state</small>
Motion sensor behaviour during slide show	Exit slideshow
Default LCD brightness	50
Dim LCD at timeout	<input type="radio"/> Enable <input checked="" type="radio"/> Disable
Door Unlock Code	
Door Unlock Code 2	
Door Unlock Code 3	
Door Unlock Code 4	

For example:

**Door Unlock Code 1111** (the code defined in **Dial Keypad 1**), will open the door associated with **Door Controller 1** (8061 IP: 172.16.1.94) and it will stay open for 3 seconds.

**Door Unlock Code 2222** (**Dial Keypad 2**) associated with **Door Controller 2** (also 8061 IP: 172.16.1.94), will open the same door and it will stay open for 30 seconds.

In this case, **Dial Keypad 1** can be used for employee access codes and **Dial Keypad 2** for guests, giving them 30 seconds to enter. This also allows for the guest **Door Unlock Code** to be changed frequently for improved security.



As illustrated in the **Door Controller 3** and **4** examples, multiple 8061 Relay Modules, each with its own password, can also be used, in a single lobby with more than one locked door that separate different businesses/units.

In this case, **Door Unlock Code 3333** on **Dial Keypad 3 (Door Controller 3)** will open a different door from **Door Unlock Code 4444** on **Dial Keypad 4 (Door Controller 4)** because two different 8061s are used in the **Door Controller** configurations.



# Appendix

## Upgrade 8036 Firmware

Periodically, new firmware for the 8036 is released that either offers new functionality or addresses problems.

This guide is based on the 1.3.8 firmware version. For new 8036 firmware updates and installation directions, please contact our support team at: (604) 454-3792 or support@algosolutions.com.



## Soft Reset

A soft reset of your 8036 may be necessary if, for example, the administrative password has been changed and then forgotten.

To do a soft reset:



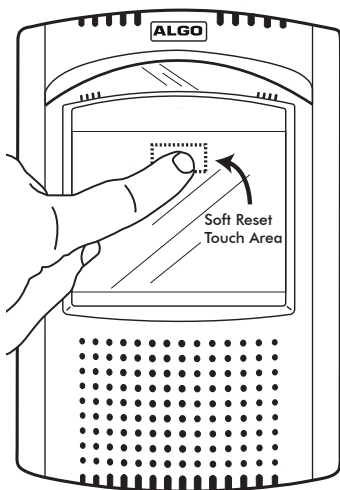

1. Disconnect the network cable from the 8036.
2. Press and hold the top middle area<sup>1</sup> of the screen until a confirmation button displays in the bottom middle area with the text description "**Press here to reset to factory default.**"
3. Press this confirmation button within five seconds, and the unit will reset itself back to factory default settings.



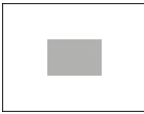

<sup>1</sup> On the 640 x 480 pixel screen, this is a rectangle area from 240(x), 40(y) to 400(x), 120(y).

## Button Positioning Table

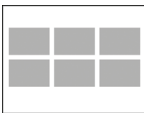
The following table provides the location and sizing of standard button layouts for 8036 User Interface Screens.

<b>Button Layout</b>		<b>Button Dimensions (in pixels) Width x Height</b>	<b>Upper Left X, Y Button Position(s) (in pixels)</b>
<i>Single Button</i>		240 x 160	200,160
<i>2 Buttons</i>		240 x 160	40, 160 360,160
<i>3 Buttons</i>		180 x 120	30,160 230,160 430,160
<i>2 x 2 Buttons</i>		200 x 120	110,120 330,120 110,260 330,260
<i>3 x 2 Buttons</i>		180 x 120	30,100 230,100 430,100 30,240 230,240 430,240

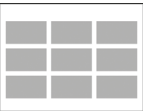
3 x 3 Buttons		180 x 100	30,20 230,20 430,20 30,140 230,140 430,140 30,260 230,260 430,260
 <i>The 3 x 3 Buttons layout is similar to 3x3 Full Screen layout below but has extra space at bottom to allow the unobstructed use of the Home and Back buttons.</i>			
3 x 3 Buttons Full Screen		180 x 100	30,80 230,80 430,80 30,200 230,200 430,200 30,320 230,320 430,320

## Adobe® Photoshop® Templates

To simplify the process of creating graphic screens with buttons that exactly line up to pre-configured 8036 button layouts, a set of Photoshop templates is available at [www.algosolutions.com/8036templates](http://www.algosolutions.com/8036templates)

Here you'll find a link to a ZIP file containing multiple Photoshop files that provide guides for laying out User Interface screens for the 8036. Each file contains guides for placing buttons that corresponds to the 8036's standard button configurations.

To use the files, open up the Photoshop file that corresponds to the button configuration you want to use. Then set Photoshop to snap to guides (**View>Snap To>Guides**). Then

use Photoshop's Rectangle Tool to draw buttons using the guides. After completing the button graphics, choose the File>Save for Web and Devices menu and use the PNG-24 preset to create the PNG file for importing into the 8036.

## Directory (Addressbook) Text Files

You can upload tab-delimited text files to the 8036 (**User Interface > Page Settings > Upload Image/Addressbook**) to create Directory pages. These Directory pages can then be used by visitors to make calls to individuals listed in the file.



As an example, here is the contents of a directory file with two fields, one for “name”, and one for “telephone extension”.

<b>Al Smith</b>	<b>1028</b>
<b>Bob Johnson</b>	<b>2156</b>
<b>John Jones</b>	<b>2345</b>
<b>Paul Phillips</b>	<b>1287</b>
<b>Terry Stevens</b>	<b>1256</b>

Note that each line represents one directory member field and that a TAB separates each field value. Note also that empty lines will result in empty lines in the Directory.

**To create a tab delimited text file using Microsoft Excel:**

1. Open your spreadsheet document go to the Windows/Office round button menu and choose Save As....
2. Change the "Save as type" or "Format" field to read: 'Text (Tab delimited)'.
3. Enter a name for the document and click Save.



*If you need your Addressbook entries sorted, you should do this when editing your text file. Note that the 8036 will not sort Addressbook entries.*

## Directory (Addressbook) Text Files

You can upload tab-delimited text files to the 8036 (**User Interface > Page Settings > Upload Image/Addressbook**) to create Directory pages. These Directory pages can then be used by visitors to make calls to individuals listed in the file.



As an example, here is the contents of a directory file with two fields, one for “name”, and one for “telephone extension”.

<b>Al Smith</b>	<b>1028</b>
<b>Bob Johnson</b>	<b>2156</b>
<b>John Jones</b>	<b>2345</b>
<b>Paul Phillips</b>	<b>1287</b>
<b>Terry Stevens</b>	<b>1256</b>

Note that each line represents one directory member field and that a TAB separates each field value. Note also that empty lines will result in empty lines in the Directory.

Please note that you can give any name to the .tar.gz file. Once the .tar.gz file is uploaded, the 8036 automatically extracts the files. To replace a file, upload the .tar.gz file again with this new file. A single file or partial group of files can also be uploaded, as long as they maintain the required folder structure and are compressed in that structure.

Note that large applications with numerous image files may take several minutes to complete the update.



## Specifications

<b>SIP Compliance</b>	RFC3261
<b>Power Input</b>	48 V PoE Class 0 (Max 12.95 W - Idle 3 W)
<b>Physical Connection</b>	RJ45
<b>LCD Display</b>	Active TFT 5.7" (14.5cm) color VGA, 80° viewing, sunlight readable, 1000:1 contrast, and 800 cd/m2 backlight
<b>Codecs Supported</b>	G.711, G.722 audio H.264 video (CIF resolution), JPEG still image
<b>Camera</b>	1/3" (8.5mm) wide VGA CMOS Digital Image Sensor; 6.0 x 6.0µm pixel size for low light performance; 110dB dynamic range
<b>Image Memory</b>	Optional to 8 GBytes
<b>Touchscreen</b>	Optically bonded projected capacitance, H7 hardness
<b>Presence Detection</b>	Area reflective 80cm range, invisible light beam
<b>Speaker</b>	Wideband 8 W
<b>Microphones</b>	Dual beam forming, wideband
<b>Hands-free</b>	Full-duplex capable, reverting to hands-free half duplex employing DSP echo cancellation and noise reduction for reliable communication in difficult outdoor environments
<b>Programmability</b>	Web interface option configuration.
<b>Environmental</b>	IP64 weather resistant; Ambient temperature: -30 to +60° C (-22 to 140° F)
<b>Compliance</b>	FCC, CSA/UL, CE
<b>Door/Gate Control</b>	Separate module SIP end point for physical security, sensing inputs, and third party equipment interfaces
<b>Dimensions</b>	Height: 10-3/4" (27.3 cm) Width: 7" (17.8 cm) Depth: 3" (7.6 cm)

*In the interests of continuing product improvement, specifications are subject to change without notice.*



*For more in-depth information on the 8036, including application notes and FAQ, please visit [www.algosolutions.com/8036](http://www.algosolutions.com/8036)*

## FCC Compliance

This equipment has been tested and found to comply with the limits for a Class A digital device, pursuant to part 15 of the FCC Rules. These limits are designed to provide reasonable protection against harmful interference when the equipment is operated in a commercial environment. This equipment generates, uses, and can radiate radio frequency energy, and if it is not installed and used in accordance with the instruction manual, it may cause harmful interference to radio communications. Operation of this equipment in a residential area is likely to cause harmful interference, in which case the user will be required to correct the interference at his own expense.

## Important Safety Notice



*The 8036 SIP Multimedia Intercom is designed and tested to comply with EN 60950-1:2006 safety requirements. When the unit is connected to wiring that exits the building, there is potential risk of lightning induced electrical surges or high voltages from fault conditions.*

*To reduce risk, outdoor wiring should be protected by Earth grounded conduit whenever possible. The 8036 is a Power over Ethernet (PoE) device. The PoE power source must be a Limited Power Source (LPS), provided by CAT5 UTP cable, and isolated from mains by minimum reinforced or double insulation. Ensure that the PoE injector or PoE enabled switch carries safety regulatory approval marks (ie CSA, UL, CE).*

# ALGO

Algo Communication Products Ltd.  
4500 Beedie Street  
Burnaby, BC Canada V5J 5L2  
[www.algosolutions.com](http://www.algosolutions.com)